

Chapter (2) Circuit Breakers

2.1 Introduction

A circuit breaker is required to perform the following three duties:

1. It must be capable of opening the faulty circuit and breaking the fault current.
2. It must be capable of being closed on to a fault
3. Must be capable of carrying fault current for a short time while another breaker is clearing the fault.

Depending on the above duties circuit breaker has three ratings breaking capacity, making capacity and short time capacity.

- **BREAKING CAPACITY**

- It is current that a circuit breaker is capable of breaking at a given recovery voltage under specified conditions. **The breaking capacity is always stated at the r.m.s value of fault current at the instant of contact separation.**

When a fault occurs there is considerable asymmetry in the fault current due to presence of d.c component. The d.c component dies away rapidly. The contacts are separated at DD' as shown in fig5

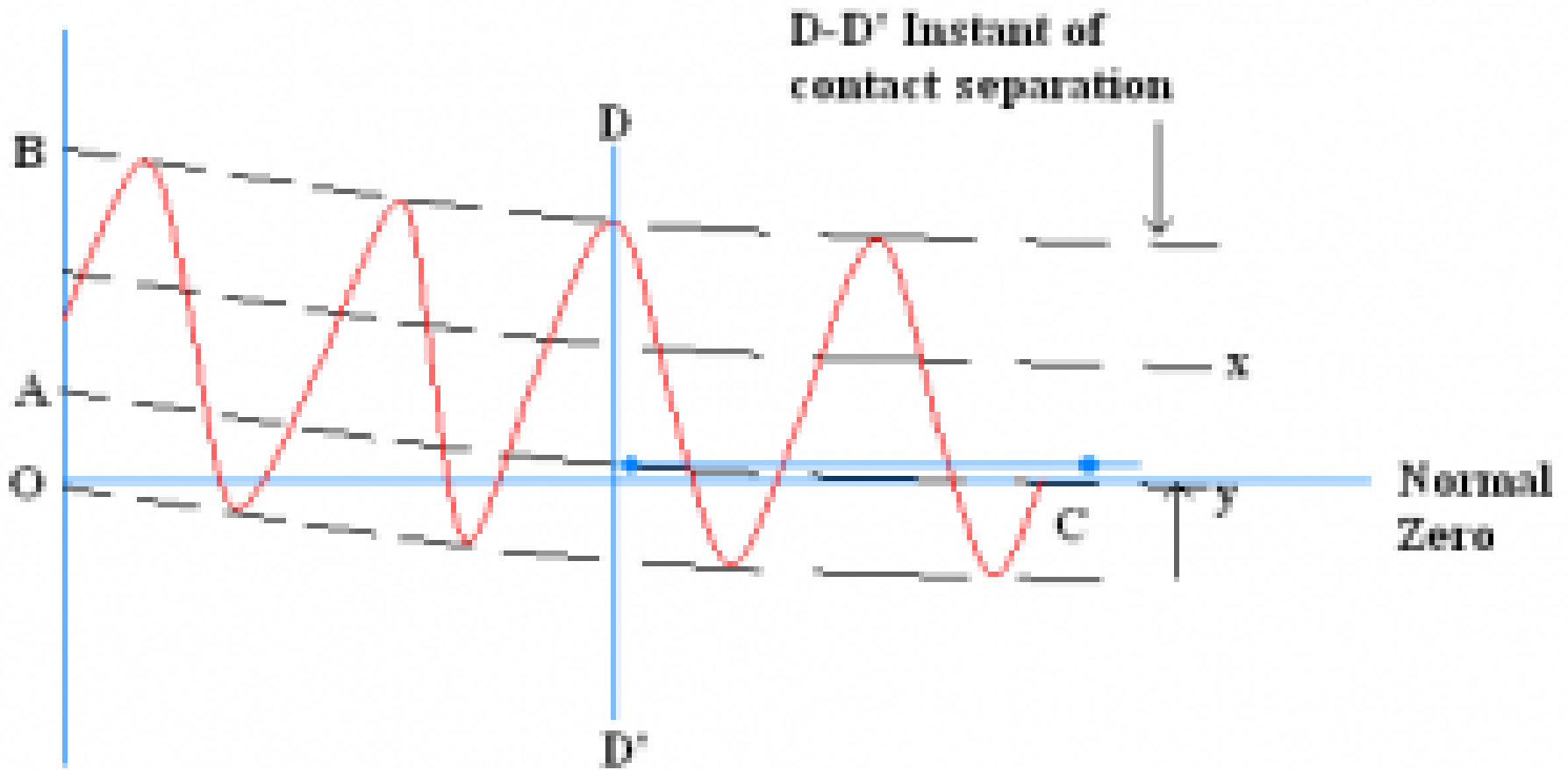

- At this point, fault current has
- $x = \text{max value of a.c component}$
- $y = \text{d.c component}$
- Therefore Symmetrical breaking current = r.m.s value of a.c component = $x / [2]^{1/2}$
- Asymmetrical breaking current = r.m.s value of a.c component = $[[x / [2]^{1/2}]^2 + y^2]^{1/2}$
- Breaking capacity is expressed in MVA by taking into account the rated breaking current and rated service voltage. Thus if I is the rated breaking current in amperes and V is rated service line voltage in volts, then for a three phase circuit breaking capacity = $\sqrt{3} * V * I * 10^{-6}$ MVA

- **MAKING CAPACITY**

- The capacity of a breaker to make current depends upon its ability to withstand and close successfully against the effects of electromagnetic forces. These forces are proportional to the square of maximum instantaneous current on closing. So making capacity is stated in terms of a peak value of current. The peak value of current during the first cycle of current wave after the closure of circuit breaker is known as making capacity. To find making capacity multiply symmetrical breaking current by root 2 to convert from r.m.s to peak and then by 1.8 to include the doubling effect of maximum asymmetry. Making capacity = $2.55 * \text{symmetrical breaking capacity}$.

- **SHORT TIME RATING**

It is the period for which the circuit breaker is able to carry fault current while remaining closed. The fault on the system of very temporary nature persist for 1 or 2 sec after which the fault will be cleared, so the breaker should not be tripped in such situations. This means the circuit breakers should be able to carry high current safely for some specified period while remaining closed. i.e they should have short time rating. It depends on its ability to withstand electromagnetic force effects and temperature rise.

2.2 Trip circuit of circuit breakers

Consider a simplified circuit of a typical relay as shown in the Fig. 1 usually the relay circuit is a three phase circuit and the contact circuit of relays is very much complicated. The Fig. 1 shows a single phase simplified circuit to explain the basic action of a relay. Let part A is the circuit to be protected. The current transformer C.T. is connected with its primary in series with the line to be protected. The secondary of C.T. is connected in series with the relay coil. The relay contacts are the part of a trip circuit of a circuit breaker. The trip circuit consists of a trip coil and a battery, in addition to relay contacts. The trip circuit can operate on a.c. or d.c.

If the fault occurs as shown in the Fig. 1, Then current through the line connected to A increases to a very high value. The current transformer senses this current. Accordingly its secondary current increases which is nothing but the current through a relay coil. Thus the relay contacts get closed mechanically under the influence of such a high fault current. Thus the trip circuit of a circuit breaker gets closed and current starts flowing from battery, through trip coil, in a trip circuit. Thus the trip coil of a circuit breaker gets energized. This activates the circuit breaker opening mechanism, making the circuit breaker open. This isolates the faulty part from rest of the healthy system.

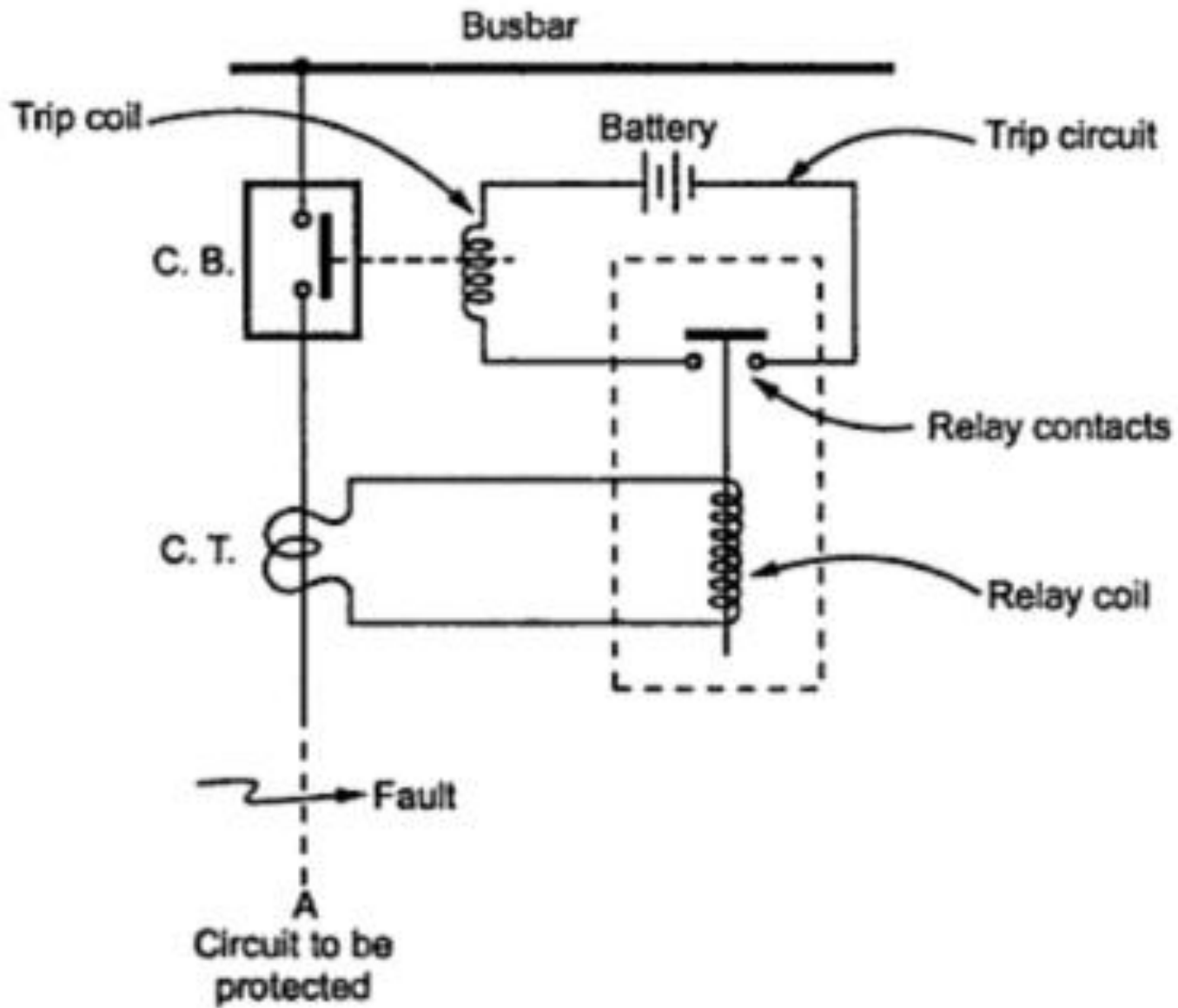

Fig.1 typical relay circuit

2.3 Tripping Schemes in Circuit Breaker

Two schemes are very popularly used for tripping in circuit breakers which are:

1. Relay with make type contact
2. Relay with break time contact

The relay with make type contact requires auxiliary d.c. supply with its operation.

while the relay with break type contact uses the energy from the main supply source for its operation. Let us see the details of these two types of schemes.

2.3.1 Relays With Make Type Contact

The schematic diagram representing the arrangement of various elements in a relay with make type contact is shown in the Fig.2.

A separate supply is necessary for the relay operation.
The relays are connected in star while the relay contacts are connected in parallel. The entire relay contact unit is connected in series with the auxiliary switch, trip coil and the battery. Relay contacts are open in normal position.

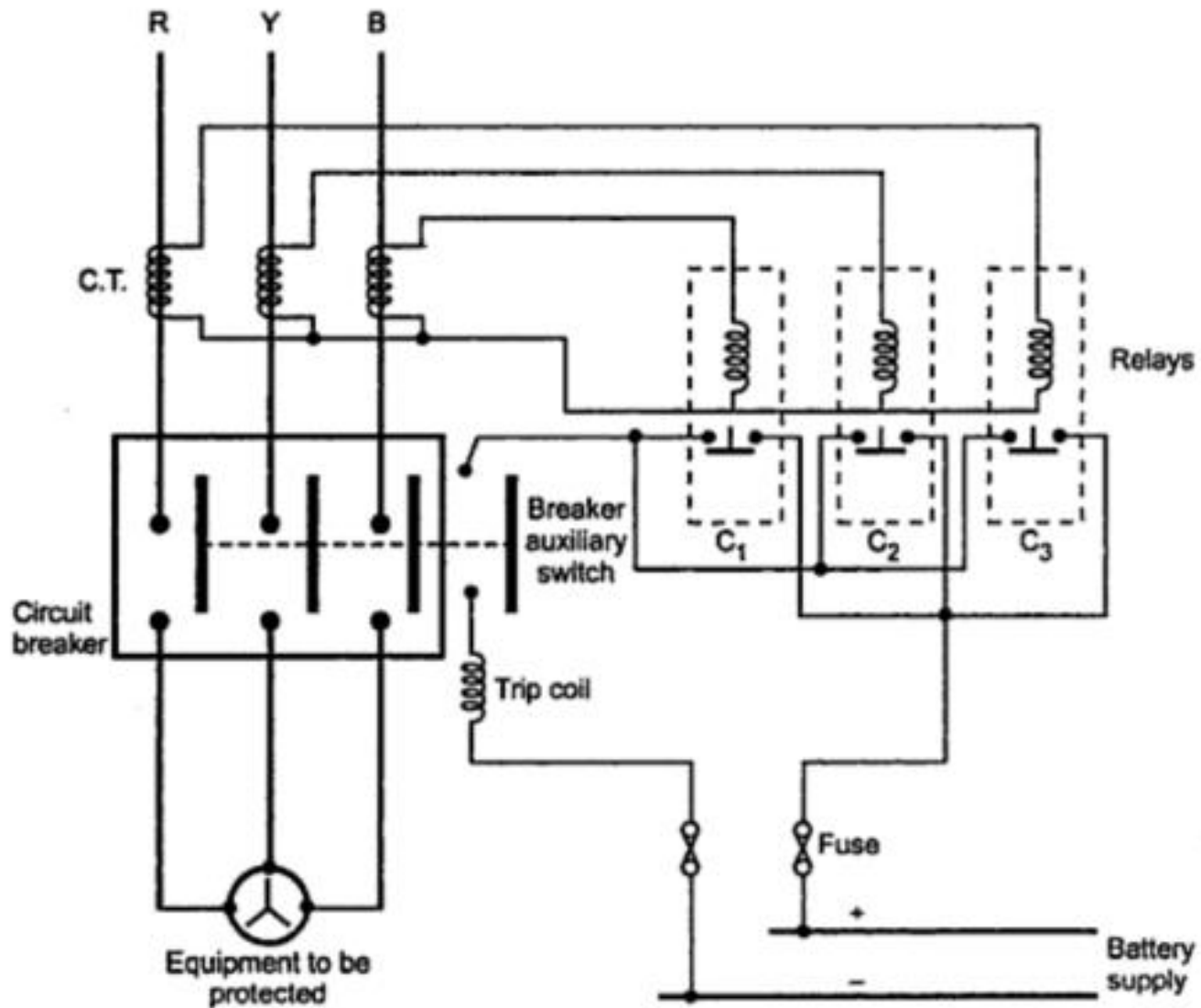

Fig. 2 Relay with make type contact

- **Operation** : When the fault occurs, the current through relay coils increases to a very high value. Due to this, **the normally open relay contacts C_1 , C_2 and C_3 get closed**. This activates the trip coil of a circuit breaker. **The auxiliary switch is initially closed along with the circuit breaker**. So when contacts C_1 , C_2 and C_3 are closed, the current flows through trip coil of circuit breaker. This activates the trip coil which opens the circuit breaker. As auxiliary switch is mechanically coupled with the circuit breaker, it also gets opened. This interrupts the current through trip coil. Thus supply to fault part gets interrupted and trip coil also gets de-energized. **This brings the relay contacts back to normal position.**

- **Due to auxiliary switch, arcing across relay contacts gets avoided. As relay contacts are normally open and they 'make' the circuit to open the circuit breaker hence called make type contact relay.**

2.3.2 Relay With Break Type Contact

The schematic arrangement of various elements in a relay with break type contact is shown in the Fig. 3.

This type of relay does not require external battery supply for the tripping. The current transformers (C.T.s) or potential transformer (P.T.s) are used to derive the energy required for the relay from the main supply source. **The relay using C.T.s to derive operating energy from the supply is shown in the Fig. 3.**

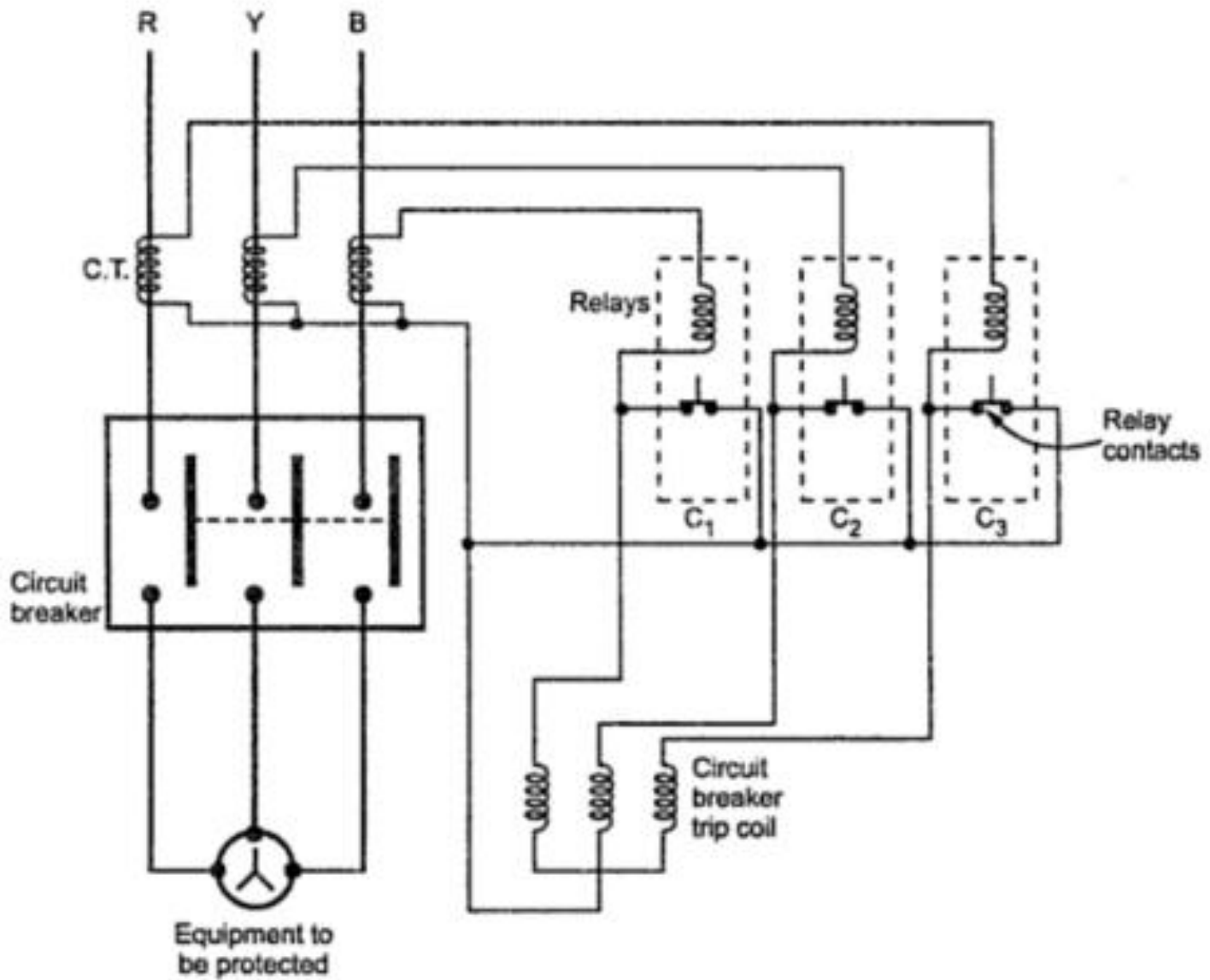

Fig.3 Relay with break type contact (using C.T.s)

- In this scheme, the relay coil and trip coil of each are connected in series. The three phases are then connected in star. Under normal working, the relay contacts C_1 , C_2 and C_3 are closed. The energy for relay coils is derived from supply using C.T.s. The trip coils of circuit breaker are de-energized under normal condition. When the fault occurs, heavy current flows through relay coils due to which relay contacts C_1 , C_2 and C_3 break. **Thus current flows through trip coils of circuit breaker due to which circuit breaker gets open.**

The Fig. 4 shows the break type contact relay using P.T. to derive energy to keep relay coils energized.

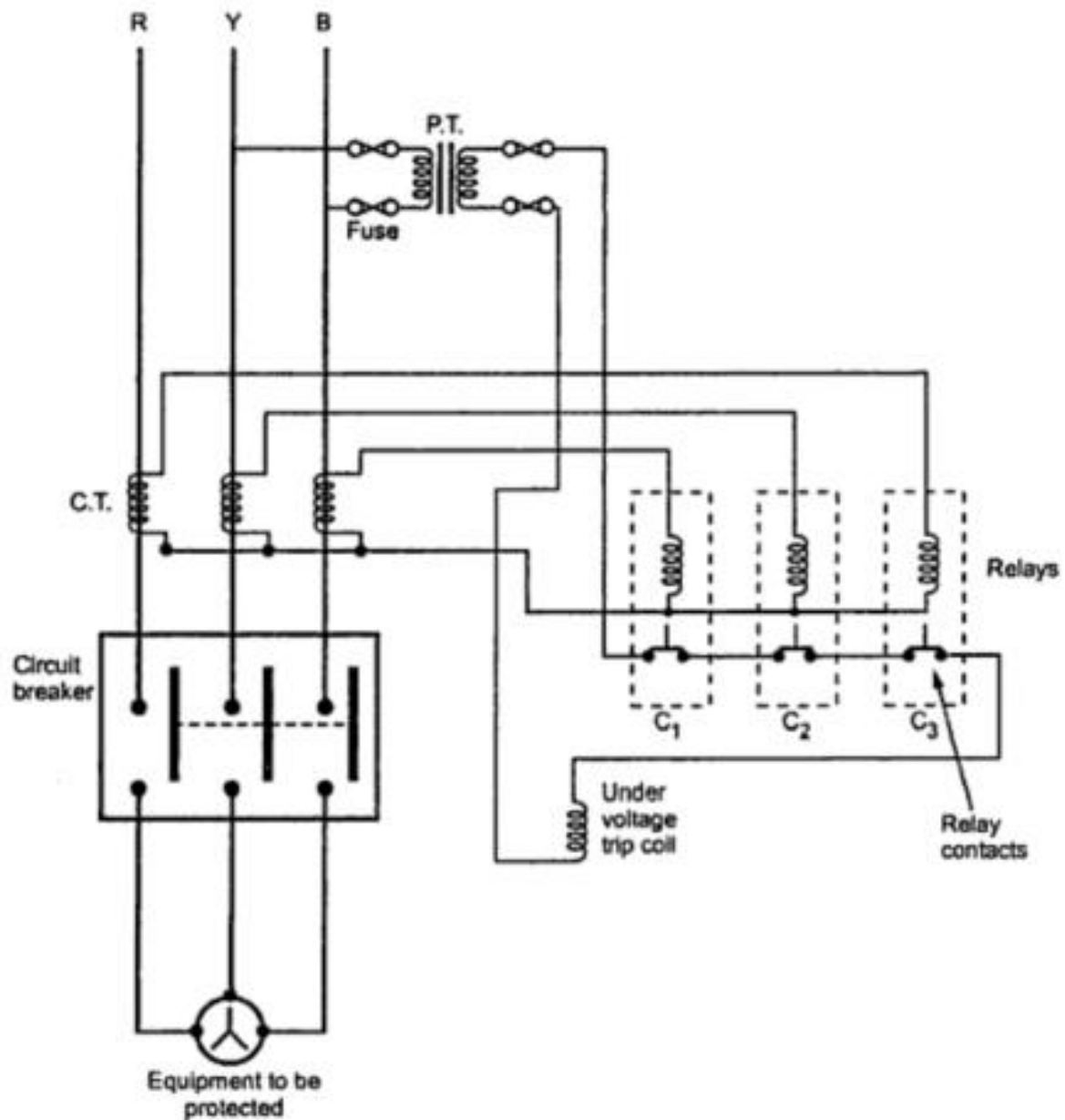

Fig.4 Relay with break type contact (using P.T.)

- In this type, in addition to normal trip coils of circuit breaker, an additional undervoltage trip coil is used. All the relay contacts are in series with the undervoltage trip coil. Through potential transformer, for normal voltage, the undervoltage trip coil is kept energized. **When the voltage becomes less than the normal value, the magnetic effect produced by undervoltage trip coil reduced which is responsible for the opening of the circuit breaker.** When fault occurs, the normal trip coils of circuit breaker comes into the picture and are responsible for the opening of the circuit breaker.

In both the above types of tripping circuit (using C.T. Or P.T.), relay contacts 'break' to cause the circuit breaker operation hence the relay is called break type contact relay.

2.4. Classification of Circuit Breakers

Circuit breakers can be arbitrarily classified using criteria such as,

1. intended voltage application,
2. Location of installation (i.e. outdoor, indoor),
3. Their external design characteristics, or perhaps the most important, method and medium used for the current interruption.

This is shown in Fig. 5.

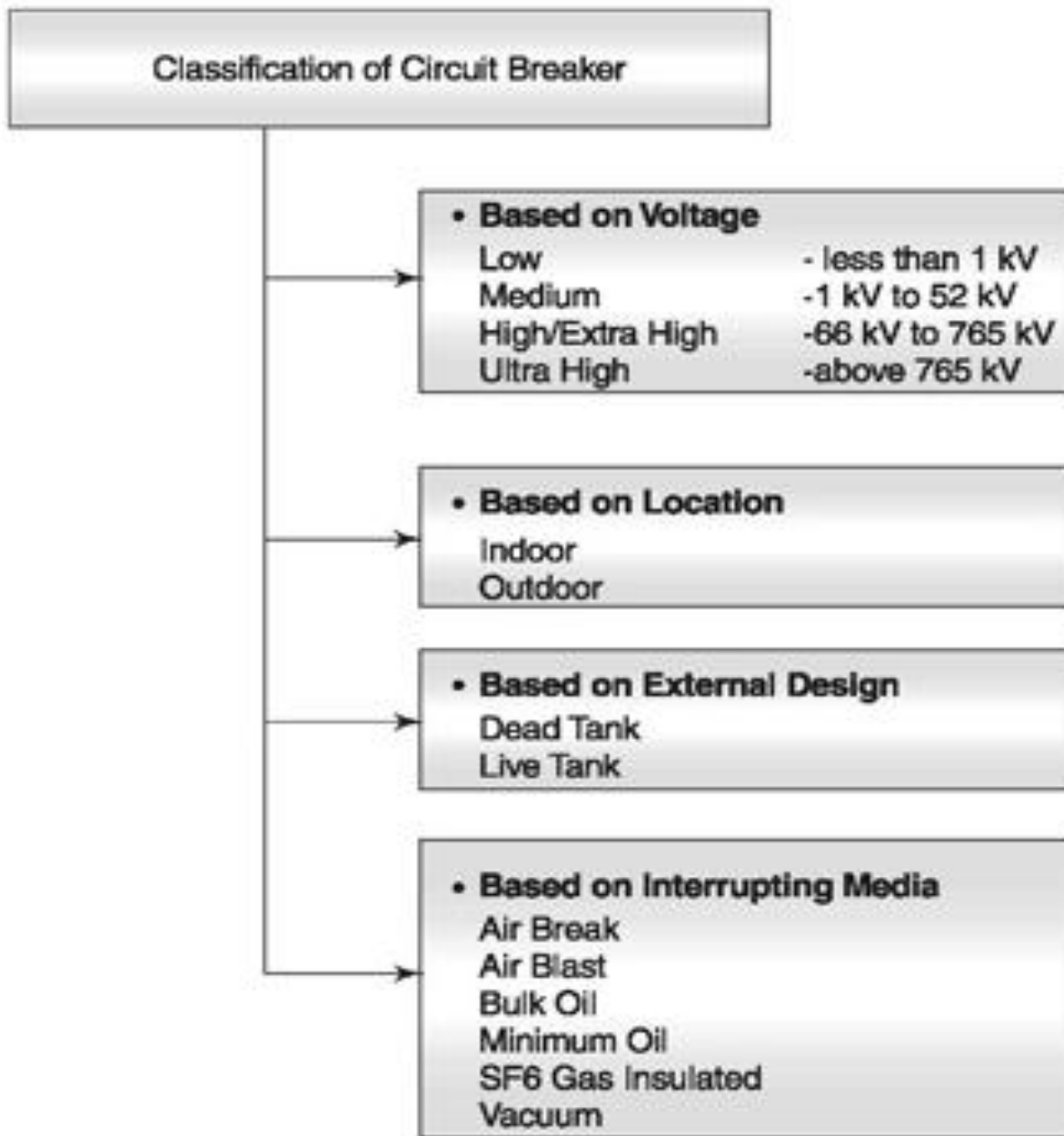

2.4.1 Classification by Voltage

The classification of circuit breakers by its intended application voltage, is normally as given in Fig. 5.

2.4.2 Classification by Location

- Switchgears, based on where they are located are classified as, **indoor and outdoor types (Fig.6)**
- **Medium and low voltage switchgears, and high voltage Gas Insulated Switchgears (GIS) are mostly categorised as Indoor switchgears, whereas the switchgears which have air as an external insulating medium, i.e. Air Insulated Switchgear (AIS), are categorised as Outdoor Switchgears.** These are shown in Fig. 6.



33 kV Indoor Type (GIS)

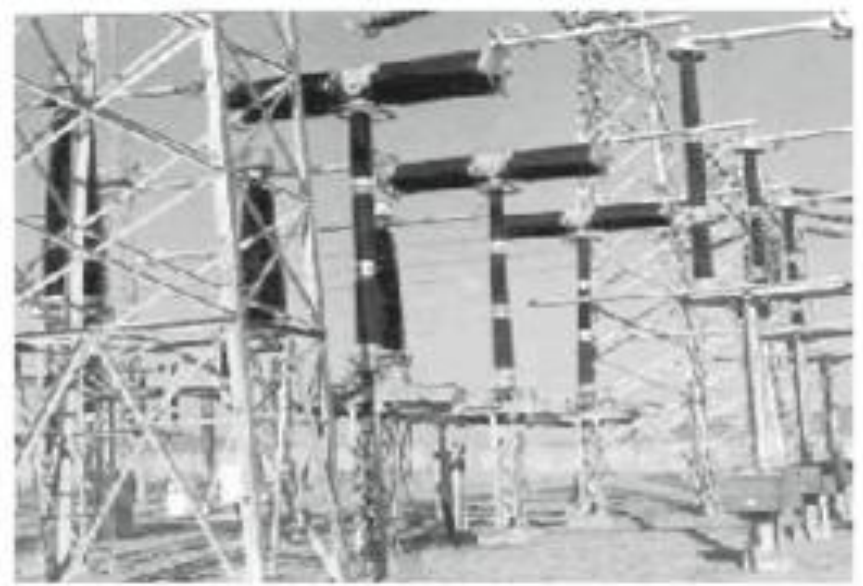

Outdoor Type (AIS)



Dead tank breaker (courtesy ABB)



Live tank breaker (Courtesy BHEL)

2.4.3 Classification by External Design

Outdoor circuit breakers can be identified as either dead-tank or live-tank type of circuit breakers, from the point of view of their physical structural design (Fig. 6).

Dead Tank C.B.

- dead-tank circuit breakers, the switching device is located, with suitable insulator supports, inside a metallic vessel(s) at ground potential and filled with insulating medium.
- In dead-tank circuit breakers, the incoming and outgoing conductors are taken out through suitable insulator bushings,
- and low voltage type current transformers are located at the lower end of both insulator bushings, i.e. at the line side and the load side.

Live Tank C.B.

In live-tank circuit breakers,

- the interrupter(s) is located in an insulator bushing, at a potential above ground potential.
- The **live-tank circuit breakers** are **cheaper** (with no current transformer),
- and **require less mounting space.**



33 kV Indoor Type (GIS)

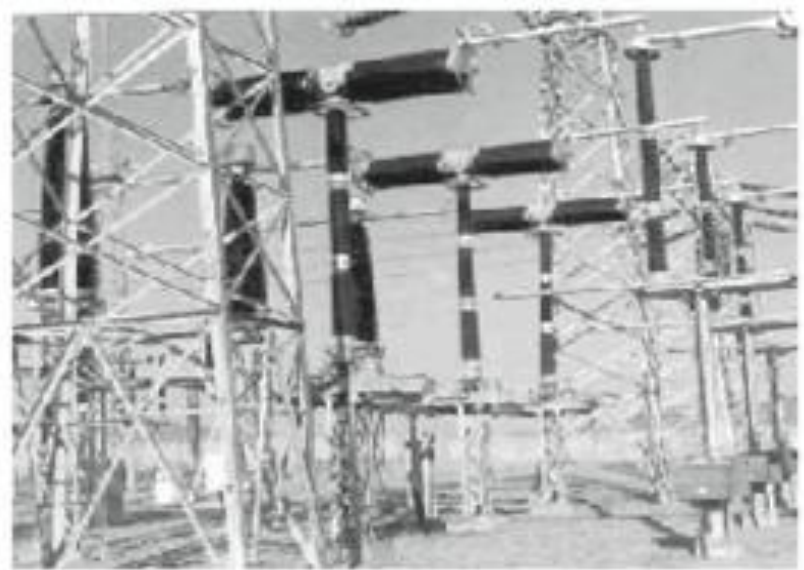

Outdoor Type (AIS)



Dead tank breaker (courtesy ABB)



Live tank breaker (Courtesy BHEL)

2.4.4 Classification by Interrupting Media

- The interrupting medium has been the vital factor in the evolution of circuit breakers. It dictates the overall design parameters of the breaker.
- The choice of air and oil, as the interrupting media, was predominant till late 70s.
- But today, **vacuum** and **Sulphur hexafluoride (SF6)** are the only dominant interrupting technologies, **for medium** and **high voltage segments** of circuit breaker design respectively.

2.5 Techniques to extinguish the arc in C. B.

- Each circuit breaker will be studied thoroughly in the subsequent sections.
- These circuit breaker employ various technique to extinguish the arc resulting from separation of the current carrying contacts.
- The mode of arc extinction is:-
 1. either 'high resistance interruption'
 2. or 'zero-point interruption'.

2.5.1 High Resistance Interruption

- **High Resistance Interruption:** In this process the resistance of the arc is increased by lengthening and cooling it to such an extent that the system voltage is no longer able to maintain the arc and the arc gets extinguished. This technique is employed in air break circuit breakers and d.c. circuit breakers.

2.5.2 Low Resistance or Zero Point Interruption

- **Low Resistance or Zero Point Interruption:** In this process, the arc gets extinguished at natural current zero of the alternating current wave and is prevented from re-striking again by rapid build-up of dielectric strength of the contacts space. This process is employed in almost all a.c. circuit breakers.

- Each leading manufacturer of circuit breaker develops two or more types of circuit breakers for every voltage class.
- The construction of the circuit breaker depends upon its type (arc-quenching medium), voltage rating and structural form.

- **Air-break circuit breaker** : Utilize air at atmospheric pressure for arc extinction.
- **Air-blast circuit breakers** : Utilize high pressure-compressed air for arc extinction. They need compressed air plant.
- **Bulk-oil and Minimum-oil circuit breaker** : utilize dielectric oil (Transformer oil) for arc extinction. In bulk-oil circuit breakers, the contacts are separated inside a steel tank filled with dielectric oil. In minimum oil circuit breakers the contacts are separated in an insulating housing (interrupter) filled with dielectric oil.

- **SF6 circuit breakers** : sulphur-Hexa-Fluoride gas is used for arc extinction. There are two types :
- **Single pressure puffer type SF6 circuit breaker**, in which the entire circuit breaker is filled with SF6 gas at single pressure (4 to 6 kg/cm²). The pressure and gas flow required for arc extinction is obtained by piston action.
- **Double pressure type SF6 circuit breaker** in which the gas from high-pressure system is released into low pressure system over the arc during the arc quenching process. This type has been superseded by puffer type.

- **Vacuum circuit breaker** : In vacuum circuit breaker the fixed and moving contacts are housed inside a permanently sealed vacuum interrupter. The arc is quenched as the contacts are separated in high vacuum.
- A brief comparison between the different types of circuit breakers is given in table 1. (see the newer post)
- Table 1 Comparison of circuit breakers

Type	Medium	Voltage. Breaking capacity	Design Feature	Remarks
1- Air- break circuit breaker	Air at atmospheric pressure	430-600 V, 5-15-35 MVA Recently 3.6-12 KV, 500 MVA	Incorporates: Arc runners, arc splitters, magnetic coils	Used for medium and low voltage, A.C., D.C., Industrial circuit breakers. Have current limiting
Miniature C.B.	Air at atmospheric pressure	430-600 KV	Small size, current limiting feature	Used for low and medium voltage
2- Tank type oil circuit breaker	Dielectric oil	12-36 KV	One tank up to 36 KV, 3 tank above 36 KV, fitted with arc control devices	Getting obsolete, used up to 12 KV, 500 MVA
3- Minimum oil circuit breaker	Dielectric oil	3.6-245 KV	The circuit breaking chamber is separate from supporting chamber. Small size, arc control device used	Used for metal enclosed switchgear up to 36 KV. Outdoor type between 36 and 245 KV
4- Air blast circuit breaker	Compressed air (20-30 kgf/cm ²)	245 KV, 35.000 MVA up to 1100 KV, 50.000 MVA, also 36 KV, 500 MVA	Unit type construction, several units per pole, auxiliary compressed air system required	Suitable for all EHV applications, fast opening-closing. Also for arc furnace duty
5- SF6 circuit breaker - single	SF6 gas (5 kgf/cm ²)	145 KV, 7500 MVA 245 KV, 10.000 MVA 12 KV, 500 MVA 36 KV, 2000 MVA	Live tank/Dead tank design, single pressure type preferred	Suitable for SF6 switchgear, and medium voltage switchgear. EHV circuit breaker. Maintenance free
6- Vacuum circuit breaker	Vacuum	Preferred for indoor switchgear rated up to 36 KV, 750 MVA	Variety of designs, long life, modest maintenance	Suitable for a variety of applications from 3.6 KV up to 36 KV
7- H.V.D.C circuit breaker	Vacuum or SF6	500 KV DC, 15 KA/20 KA	Artificial current zero by switching in capacitors	Recently developed, used in HVDC systems. Installed in USA

2.6 Rated characteristic of circuit breakers

- The rating of a circuit breaker denote its capabilities under specified condition of use and behaviour. The following paragraphs are generally based on the recommendation of IEC-56: "High Voltage Alternating Current Circuit-Breakers" and IS-2516: " Specifications of Alternating current circuit-breaker".
- The capabilities of a circuit breaker of a particular type are proved by conducting type tests as per the recommendations of the standards.

2.6.1 Rated Voltage

- The rated voltage of a circuit-breaker corresponds to the higher system voltage for which the circuit breaker is intended. The standards values of rated voltages are given in table 2. **The rated voltage is expressed in KVrms** and refers to phase to phase voltage for three-phase circuit. The earlier practice of specifying the rated voltage of a circuit breaker as nominal system voltage is no more followed.

Table 2 : Rated Voltage of Circuit Breaker

Nominal System Voltage (KVrms)	Rated Voltage of Circuit Breaker (KVrms)
1.240	1.246
1.410	1.440
3.300	3.600
6.600	7.200
11.000	12.000
22.000	24.000
33.000	36.000
66.000	72.000
132.000	140.000
220.000	240.000
400.000	420.000
500.000	520.000
750.000	760.000

2.6.2 Rated Insulation Level of C.B.

- The rated insulation level of a circuit breaker refers to:-
 1. The power frequency withstand voltage and
 2. Impulse voltage withstand values
which characterize the insulation of the circuit breaker.

Causing of Power-frequency over voltages

- Power-frequency over voltages are due to regulation, ferranti effect, higher tap-setting, etc. The circuit breaker should be capable of withstanding the power frequency over-voltages which are likely to occur. **These capabilities are verified by conducting power frequency voltage withstand tests and impulse voltage withstand tests.** The circuit breaker is subjected to impulse over-voltage due causes like lighting surge and switching surge.

- During single-line to ground faults, the voltage of healthy lines to earth increases to $\sqrt{3}$ time the normal value in the system with insulated neutral. Hence higher values of insulation are recommended for circuit breaker connected in noneffectively earthed systems. The following insulations are provided in the circuit breaker :
 - Insulation between live parts and earth for each pole external and internal.
 - Insulation between poles.
 - Insulation between terminals of the same pole-external and internal

The design of these insulations depends upon the structural form of the circuit breaker and the rated insulation level desired.

2.6.3 Rated Frequency

- The standard frequency for a three pole circuit breaker is the frequency of the power system (50/60 HZ). The characteristics like normal current breaking capacity etc. are based on the rated frequency.
- The frequency of the current influences the circuit breaker behaviour as follows:

- The temperature rise of current carrying parts and neighbouring metallic parts is influenced by eddy-current heating . The increase in frequency results in increased eddy currents. Hence, with specified limits of the temperature rise the rated current of a circuit breaker needs de-rating for application on higher frequency.
- The frequency corresponds to the number of current-zeros per second. Since the breaking time of the circuit breaker is associated with the time for half cycles during the arc extinguishing process, the breaking time is influenced by the frequency of current. The breaking time increases with reducing in frequency.

- The increase in frequency influences the TRV and rate-of-rise TRV. Hence a circuit breaker designed and rated for a certain frequency cannot be recommended for other frequencies unless capabilities are proved for those frequencies.
- The d.c. circuit breakers generally adopt a different principle of arc extinction and have different construction than a.c. circuit breaker

2.6.4 Rated Normal Current (Rated Current)

- The rated normal current of a circuit breaker is the r.m.s value of the current which the circuit breaker can carry continuously and with temperature rise of the various parts within specified limits. Preferred values of rated current in A_{rms} are 400, 630, 800, 1250, 1600, 2000, 2500, 3150, and 4000.

- The design of contacts and other current carrying parts in the interrupter of the circuit breaker are generally based on the limits of the temperature rise. For a given cross-section of the conductor and a certain value of current, the temperature rise depends upon the conductivity of the material. Hence, high conductivity material is preferred for current carrying parts. The cross-section of the conductors should be increased for materials with lower conductivity. The use of magnetic materials in close circuits should be avoided to prevent heating due to hysteresis loss and eddy currents. The rated current of a circuit breaker is verified by conducting temperature rise tests.

2.6.5 Rated Short Circuit Breaking Current

- The rated short circuit breaking current of a circuit breaker is the highest rms value of short circuit current which the circuit breaker is capable of breaking under specified conditions of transient recovery voltage and power frequency voltage. It is expressed in KA rms at contact separation.

- Referring to Fig. 2, the short circuit current has a certain value at the instant of contact separation, ($t = T_1$). The breaking current refers to value of current at the instant of the contact separation.

The transient recovery voltage refers to the transient voltage appearing across the circuit breaker pole immediately after the arc interruption.

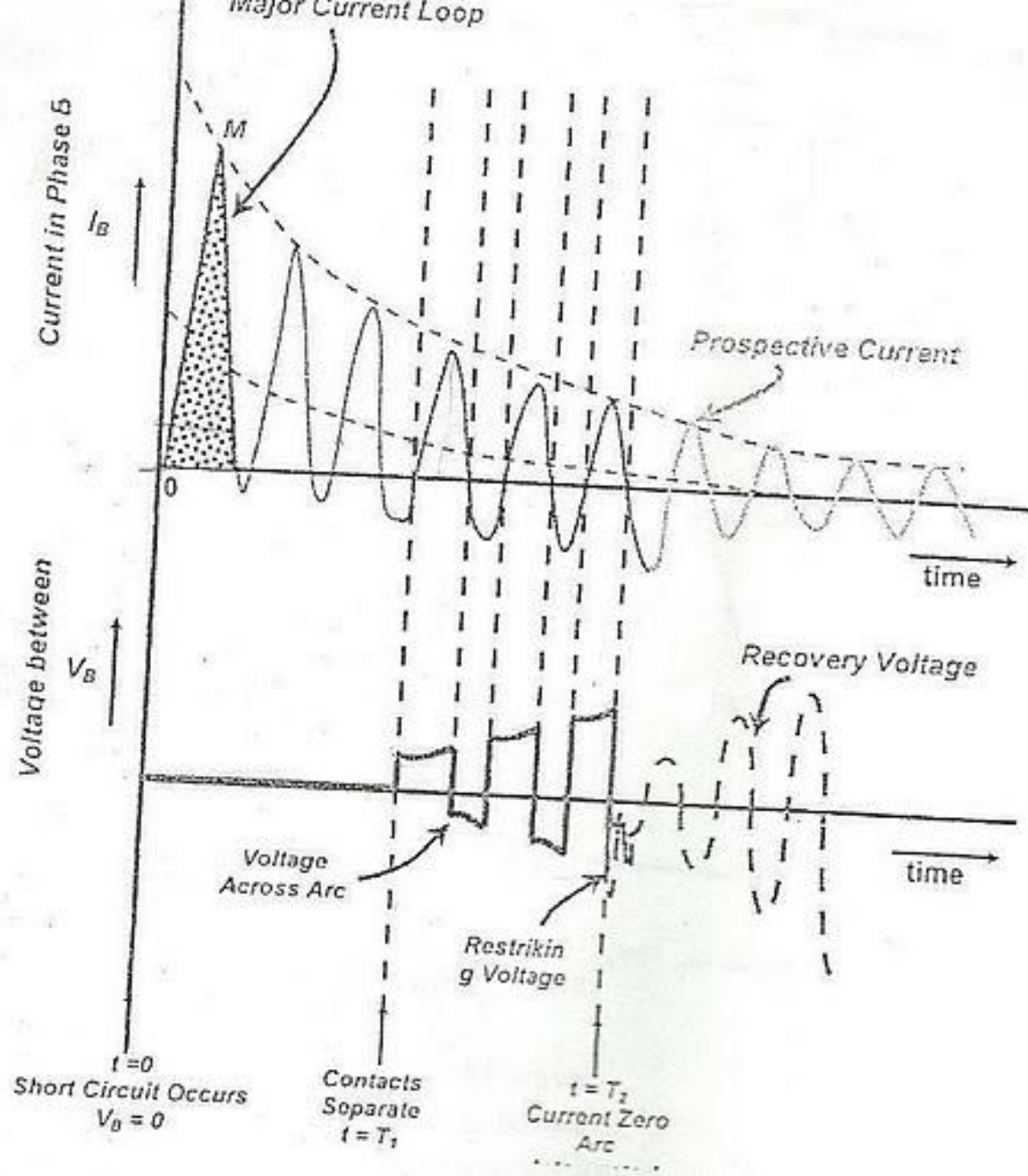
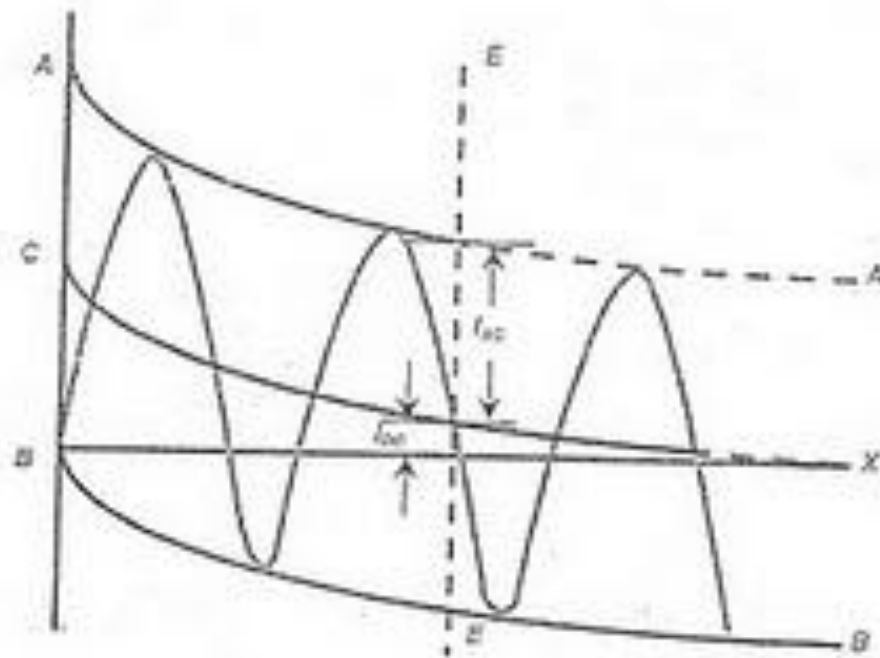

Figure 2 Oscillogram of Current and Voltage during fault clearing

- The rated values of transient recovery voltage are specified for various rated voltage of circuit breakers. For specified conditions of rated TRV and rated power frequency recovery voltage, a circuit breaker has a certain limit of breaking current.
- This limit is determined by conducting short circuit type tests on the circuit breaker. The waveforms of short circuit current are obtained during the breaking test. **The evaluation of the breaking current is explained in Fig. 3. The breaking current is expressed by two values :**



- AA
- BB
- BX
- CX
- EE
- I_{ac}
- I_{dc}
- $\frac{I_{dc} \times 100}{I_{ac}}$
- $\frac{I_{dc}}{\sqrt{2}}$

= Envelope of current wave

= Normal zero axis of wave

= Displaced zero axis of wave

= Instant of contact separation

= Peak value of A.C. component of current at EE

= D.C. component of current at EE

= Percentage of D.C. component at the instant EE

= r.m.s. value a.c. component.

Figure 3 Dimension of breaking current.

1. The r.m.s value of a.c. component at the instant of contact separation $E E$, given by $(I_{dc} / \text{Square root of } 2)$
2. The percentage d.c. component at the instant of contact separation given by $(I_{dc} \times 100 / I_{Ac})$

The r.m.s values of a.c. components are expressed in KA. the standard values being 8, 10, 12.5, 16, 20, 25, 31.5, 40, 45, 63, 80 and 100KA.

The earlier practice was to express the rated breaking capacity of a circuit breaker in terms of MVA given as follows

$$\text{MVA} = \sqrt{3} \times \text{KV} \times \text{KA}$$

Where

MVA = Breaking capacity of a circuit breaker

kV = Rated voltage

kA = Rated breaking current

- This practice of specifying the breaking capacity in terms of MVA is convenient while calculating the fault levels. However, as per the revised standards, the breaking capacity is expressed in KA for specified conditions of TRV and this method takes into account both breaking current and TRV.
- While selecting the circuit breaker for a particular location in the power system the fault level at that location is determined. The rated breaking current can then be selected from standard range.

2.6.6 Rated Short Circuit Making Current

- It may so happen that circuit breaker may close on an existing fault. In such cases the current increase to the maximum value at the peak of first current loop. The circuit breaker should be able to close without hesitation as contact touch. The circuit breaker should be able to withstand the high mechanical forces during such a closure. These capabilities are proved by carrying out making current test. The rated short circuit making current of a circuit breaker is the peak value of first current loop of short circuit current (I_{pk}) which the circuit breaker is capable of making at its rated voltage.

- The rated short circuit making current should be least 2.5 times the r.m.s. value of a.c. component of rated breaking current .
- Rated making current = $1.8 \times \sqrt{2} \times$ Rated short circuit breaking
= $2.5 \times$ Rated short circuit breaking current
- In the above equation the factor $\sqrt{2}$ convert the r.m.s value to peak value. Factor 1.8 takes into account the doubling effect of short circuit current with consideration to slight drop in current during the first quarter cycle .

2.6.7. Circuit Breaker Time (total break time)

- Fault clearing time is the sum of "relay time" and "circuit breaker time". Circuit breaker time is also called "total break time"
- The rapid fault clearing of extra high voltage transmission lines improves the power system stability. Hence, faster relaying and fast circuit breaker are preferred for extra high voltage transmission lines, where the circuit breaker time being in order of 2.5 cycles.

Item		Unit	Technical Data		
			LW10-252 (CY/CYT)		LW10B-363 (CYT)
Rated voltage		kV	252	363	550
Rated frequency		Hz	50		
Rated current		A	3150,4000		
Rated short circuit breaking current		kA	40/50	63	63
Rated short line fault breaking current		kA	36/45	56.7	56.7
Rated out of phase breaking current		kA	10/12.5	15.75	15.75
Rated peak withstand current		kA	100/125	160	160
Rated short circuit making current (peak)		kA	100/125	160	160
Rated short time withstand current		kA	40/50	63	63
Rated duration of short circuit		S	3		
Rated line charging breaking current (r.m.s)		A	160	500	500
Breaking time of rated short circuit current		times	20		
Mechanical endurance		times	5000/1000		
Rated SF ₆ gas pressure at 20 °C		Mpa	0.4/0.6	0.6	0.6
SF ₆ gas moisture content (Ex-work)		PPM	≤150		
SF ₆ gas leakage rate (per year)		%	≤1		
SF ₆ gas weight (per pole)		kg	6 (without closing resistance)/10(with closing resistance)	12 (without closing resistance)/15(with closing resistance)	20 (without closing resistance)/25(with closing resistance)
Circuit Breaker weight (per pole)		kg	1600 (without closing resistance)/1800(with closing resistance)	2530 (without closing resistance)/3180(with closing resistance)	2840(without closing resistance)/3800(with closing resistance)
Operation force for opening/closing		kN	76/38	130/60	130/60
Terminal load	Longitudinal	N	2250	1500	2800
	Horizontal	N	1768	1000	2400
	Vertical	N	1250	1250	

- For distribution system, such a fast clearing is not necessary. Discrimination is obtained by "graded time lag". Hence, slower circuit breaker, 3 to 5 cycles, are used.
- Total breaking time varies between 80-120 ms for circuit breaker up to 12KV and 40-80 ms for circuit breaker above 36KV. It is less than 60 ms for 145KV, less than 50 ms for 420 KV circuit breaker.

Fault clearing Time

- Remember the following time events :
- **Fault clearing time** = relay time + circuit breaker time
- **Relay time** = instant of fault **to** closure of trip circuit
- **Circuit breaker time** = opening time + arcing